

SmartMesh WirelessHART Network Manager Wireless Embedded Network Manager

NETWORK FEATURES

- Complete **Radio Transceiver, Embedded Processor, and Networking Software** for Forming a Self-Healing Mesh Network
- Compliant to WirelessHART (IEC62591) Standard
- SmartMesh Networks Incorporate:
 - Time Synchronized Network-Wide Scheduling
 - Per Transmission Frequency Hopping
 - Redundant Spatially Diverse Topologies
 - Network-Wide Reliability and Power Optimization
- NIST Certified Security
- SmartMesh Networks Deliver:
 - >99.999% Network Reliability Achieved in the Most Challenging Dynamic RF Environments Often Found in Industrial Applications
 - Sub 50µA Routing Nodes

LTP5903-WHR FEATURES

- Manages Networks of Up to 250 Nodes (LTP5903-WHRB) or Up to 500 Nodes (LTP5903-WHRC)
- Dynamic network optimization maintains network health and enables greater than 99.999% network reliability even in the most challenging environments
- Comprehensive APIs deliver rich and flexible functionality without complex coding
- RF Modular Certifications Include USA, Canada, EU, Japan

DESCRIPTION

SmartMesh® WirelessHART wireless sensor networks are self managing, low power networks built from wireless nodes called motes. The [LTP™5903-WHR](#) SmartMesh WirelessHART embedded manager is the printed circuit board assembly product running Dust's embedded Smart-Mesh WirelessHART networking software. The LTP5903-WHR is designed for use in line-powered gateways and controllers, such as WirelessHART Gateways, and enables customers to integrate a standards-based wireless sensor network that provides scalable bidirectional communications.

Compliant to the WirelessHART (IEC62591) standard, the LTP5903-WHR runs SmartMesh WirelessHART network management software to monitor and manage network performance and provide a data ingress/egress point via Ethernet and UART interfaces. The SmartMesh WirelessHART software provided with the LTP5903-WHR is fully tested and validated, and is readily configured via a software application programming interface. With Dust's time-synchronized SmartMesh WirelessHART networks, all motes in the network may route, source or terminate data, while providing many years of battery powered operation.

SmartMesh WirelessHART motes deliver a highly flexible network with proven reliability and low power performance in an easy-to-integrate platform.

LT, LT, LTC, LTM, Linear Technology, Dust, Dust Networks, Eterna, SmartMesh and the Linear logo are registered trademarks and LTP and the Dust Networks logo are trademarks of Linear Technology Corporation. All other trademarks are the property of their respective owners.

Protected by U.S. Patents, including 7375594, 7420980, 7529217, 7791419, 7881239, 7898322, 8222965.

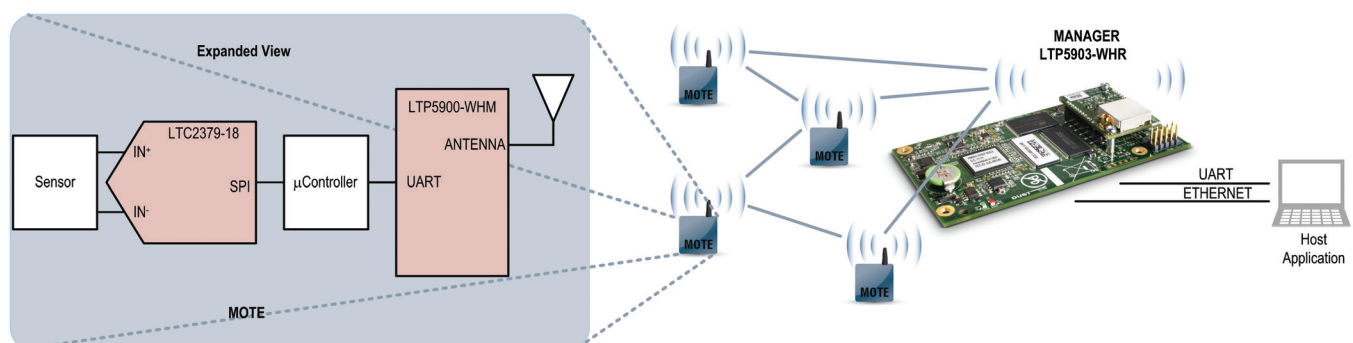

Table of Contents

1.0	Absolute Maximum Ratings	4
2.0	Normal Operating Conditions	4
3.0	Electrical Specifications	4
3.1	LVTTTL I/O DC Specifications	5
3.2	LED Specifications.....	6
3.3	3.3 V Output Supply.....	6
3.4	Device Load	6
3.5	AC Timing Specifications	6
4.0	Real-time Clock	6
5.0	Radio	6
5.1	Detailed Radio Specifications	6
5.2	Antenna Specifications.....	8
6.0	SmartMesh WirelessHART Intelligent Networking Platform	8
6.1	Dynamic Network Optimization	8
6.2	Deterministic Power Management.....	8
6.3	Intelligent Routing	8
6.4	Bandwidth Flexibility	9
7.0	Interfaces	9
7.1	Hardware Interfaces.....	9
7.1.1	10/100Base-T Ethernet Interface	9
7.1.2	Serial 1 Interface.....	9
7.1.3	Serial 2 Interface.....	9
7.1.4	SD Card Interface	10
7.1.5	LED Status Indicators.....	10
7.1.6	Restore Signal.....	10
7.2	Software Interfaces.....	12
7.2.1	XML API	12
7.2.2	Admin Toolset	12
7.2.3	Command Line Interface.....	12
8.0	Board-to-board Connectors	12
8.1	Connector Pin Numbering.....	12
8.2	Pinout	13
8.3	Recommended Mating Connectors.....	15
9.0	Mechanical Specifications	15
9.1	LTP5903-WHR Mechanical Drawings	15
10.0	Regulatory and Standards Compliance	16
10.1	FCC Compliance	16
10.1.1	FCC Testing	16
10.1.2	FCC-approved Antenna.....	17

10.1.3 OEM Labeling Requirements	17
10.2 IC Compliance	17
10.2.1 IC Testing.....	17
10.2.2 IC-approved Antennae	17
10.2.3 OEM Labeling Requirements	17
10.3 CE Compliance	18
10.3.1 Declaration of Conformity	18
10.3.2 European Compliance.....	18
10.3.3 OEM Labeling Requirements	18
10.3.4 Restrictions.....	18
10.4 Compliance to Japan Radio Law	18
10.4.1 OEM Labeling Requirements	18
10.4.2 Antenna Selection.....	19
10.5 Compliance to Restriction of Hazardous Substances (RoHS)	19
10.6 Industrial Environment Operation.....	19
11.0 Order Information.....	19
12.0 Related Documentation.....	19

1.0 Absolute Maximum Ratings

The absolute maximum ratings shown below should not be violated under any circumstances. Permanent damage to the device may be caused by exceeding one or more of these parameters.

Table 1 Absolute Maximum Ratings

Parameter	Min	Typ	Max	Units	Comments
Supply voltage (+5V_IN to GND)	-0.3		6	V	
Input RF level			10	dBm	Input power at antenna connector
Storage temperature range	-40		+85	°C	
VSWR of antenna			3:1		
ESD protection					
Antenna connector			±8000	V	HBM
All other connectors			±2	kV	HBM
			±200	V	CDM

All voltages are referenced to GND



Caution! ESD sensitive device. Precaution should be used when handling the device in order to prevent permanent damage.

2.0 Normal Operating Conditions

Table 2 Normal Operating Conditions

Parameter	Min	Typ	Max	Units	Comments
Operational supply voltage range (between +5V_IN and GND)	4.0	5.0	5.5	VDC	Including noise and load regulation
Voltage supply noise			100	mV _{p-p}	50 Hz–50 MHz
Peak current			350	mA	+3V3 out = 0 mA
Average current		150		mA	+5V_IN at 5.0 V, 25 °C, +3V3 out = 0 mA
		225		mA	+5V_IN at 5.0 V, 25 °C, +3V3 out = 100 mA
Operating temperature range	-40		+85	°C	
Maximum allowed temperature ramp during operation			8	°C/min	-40 °C to +85 °C
Operating relative humidity	10		90	% RH	Non-condensing

The specifications listed are for the power supply connected to +5V_IN and GND, and apply over the operating temperature range unless otherwise specified.

3.0 Electrical Specifications

I/O specifications are given below for each I/O level type given in the board-to-board connector tables in sections 7.1 and 8.2. Unless otherwise noted, +5V_IN is 5.0 V and temperature is -40 °C to +85 °C.

3.1 LVTTTL I/O DC Specifications

Table 3 LVTTTL Type 1 Specifications

Parameter	Min	Typ	Max	Units	Comments
V _{IH} (logical high input)	2.0		3.6	V	
V _{IL} (logical low input)	-0.3		0.8	V	
I _{IN} (input leakage)			60	μA	
V _{OH} (logical high output)	2.6			V	
V _{OL} (logical low output)			0.4	V	
I _{OH} (V _O = V _{OH}) (source)	8			mA	
I _{OL} (V _O = V _{OL}) (sink)	8			mA	

Table 4 LVTTTL Type 2 Specifications (Schmitt Trigger)

Parameter	Min	Typ	Max	Units	Comments
V + Threshold	1.3		2.5	V	
V – Threshold	0.6		1.6	V	
I _{IN} (input leakage)			±5	μA	V _{IN} = +3V3

Table 5 LVTTTL Type 3 Specifications

Parameter	Min	Typ	Max	Units	Comments
V _{OH}	2.6			V	
V _{OL}			0.4	V	
I _{OH}	-12			mA	
I _{OL}	12			mA	

Table 6 LVTTTL Type 4 Specifications

Parameter	Min	Typ	Max	Units	Comments
V _{OH} (logical high output)	2.6		+3V3	V	
V _{OL} (logical low output)	GND		0.4	V	
I _{OH} (V _O = V _{OH}) (source)	2			mA	
I _{OL} (V _O = V _{OL}) (sink)	2			mA	

Table 7 LVTTTL Type 5 Specifications

Parameter	Min	Typ	Max	Units	Comments
V _{IH} (logical high input)	2.6		+3V3 + 0.3	V	
V _{IL} (logical low input)	GND – 0.3		GND + 0.8	V	
I _{IN} (input leakage)			±5	μA	V _{IN} = +3V3

3.2 LED Specifications

Table 8 LED Specifications

Parameter	Min	Typ	Max	Units	Comments
V _{OH} (logical high output)	+3V3 – 0.3		+3V3	V	
V _{OL} (logical low output)	GND		GND + 0.4	V	
I _{OH} (V _O = V _{OH}) (source)	3			mA	+3V3 = 3.3 V
I _{OL} (V _O = V _{OL}), I/O = LED (sink)	1.5			mA	+3V3 = 3.3 V
I _{OL} (V _O = V _{OH}), I/O = LED low (sink)	0.5			mA	+3V3 = 3.3 V

3.3 3.3 V Output Supply

The LTP5903-WHR includes a regulated 3.3 V output signal (labeled +3V3) for supplying power to user circuitry (for example, isolation or signal conditioning). Note that any power drawn on +3V3 circuitry results in an increase in power drawn on +5V_IN.

Table 10 +3.3 V Power Supply Output

Parameter	Min	Typ	Max	Units	Comments
+3V3 current source			100	mA	
+3V3 supply voltage	3.13		3.47	V	

3.4 Device Load

Table 11 Device Load

Parameter	Min	Typ	Max	Units	Comments
Total capacitance			290	μF	
Total inductance			15	μH	

3.5 AC Timing Specifications

Table 12 AC Timing Specifications

Parameter	Min	Typ	Max	Units	Comments
nRESET_IN pulse width	125			μs	

4.0 Real-time Clock

The LTP5903-WHR has a battery-backed real-time clock (RTC) with a typical lifetime of 5-7 years (lifetime up to 15 years if the manager is normally powered), assuming the manager is operating at 60 °C average ambient temperature and at 10% duty cycle. Upon bootup, the RTC initializes the software system clock that handles timekeeping while the system is operating.

The software system clock is the reference for UTC time values readable through the software APIs, command line interface (CLI) and Admin Toolset Web interface, as well as the UTC time values visible in manager log files. The system clock may be set manually using the Admin Toolset Web interface, or through the Linux command shell. The accuracy of the software system clock is typically 1 min/month at 25°C, though may vary as much as 10 min/month at temperature extremes. To support applications less tolerant of such drift, the LTP5903-WHR software includes an NTP client to periodically synchronize software system time to an outside source. The NTP client is configurable using the Admin Toolset Web interface, or through the Linux command shell.

5.0 Radio

5.1 Detailed Radio Specifications

Table 13 Radio Specifications

Parameter	Min	Typ	Max	Units	Comments
Operating frequency	2.4000		2.4835	GHz	

Parameter	Min	Typ	Max	Units	Comments
Number of channels		15			
Channel separation		5		MHz	
Occupied channel bandwidth		2.7		MHz	At -20 dBc
Frequency accuracy	-40		+40	ppm	
Modulation					IEEE 802.15.4 DSSS
Raw data rate		250		Kbps	
Receiver operating input level		0		dBm	
Receiver sensitivity		-92.5		dBm	At 50% PER, $V_{DD} = 3\text{ V}$, 25 °C
		-90		dBm	At 1% PER, $V_{DD} = 3\text{ V}$, 25 °C, (inferred by 50% PER measurement)
Output power, conducted					
Power amplifier enabled:					
At 25 °C		+8		dBm	
Power amplifier disabled:					
At 25 °C		-2		dBm	
Range*					
Power amplifier enabled:					
Indoor [†]		100		m	25 °C, 50% RH, +2 dBi omni-directional antenna
Outdoor [†]		300		m	
Free Space		1200		m	
Power amplifier disabled:					
Indoor [†]		25		m	25 °C, 50% RH, +2 dBi omni-directional antenna
Outdoor [†]		200		m	
Free Space		350		m	
<p>*Actual RF range performance is subject to a number of installation-specific variables including, but not restricted to ambient temperature, relative humidity, presence of active interference sources, line-of-sight obstacles, near-presence of objects (for example, trees, walls, signage, and so on) that may induce multipath fading. As a result, actual performance varies for each instance.</p> <p>[†] 1 meter above ground.</p>					

5.2 Antenna Specifications

A MMCX-compatible jack receptacle is provided on board for the antenna connection. For antenna location, refer to the mechanical drawing in section 9.1. The antenna must meet specifications in Table 14. For a list of antennae pre-approved for RF certification, see section 10.1.2.

Table 14 Antenna Specifications

Parameter	Value
Frequency range	2.4–2.4835 GHz
Impedance	50 Ω
Gain LTP5903-WHR	+2 dBi maximum
Pattern	Omni-directional
Maximum VSWR	3:1
Connector	MMCX*
* The LTP5903-WHR can accommodate the following RF mating connectors: <ul style="list-style-type: none">• MMCX straight connector such as Johnson 135-3402-001, or equivalent• MMCX right angle connector such as Tyco 1408149-1, or equivalent	

When the LTP5903-WHR is placed inside an enclosure, the antenna should be mounted such that the radiating portion of the antenna protrudes from the enclosure, and connected using a MMCX connector on a coaxial cable. For optimum performance, allow the antenna to be positioned vertically when installed.

6.0 SmartMesh WirelessHART Intelligent Networking Platform

The SmartMesh WirelessHART LTP5903-WHR embedded network manager is built upon Dust Networks' Intelligent Networking Platform, which provides dynamic network optimization, deterministic power management, intelligent routing, and bandwidth flexibility to achieve the carrier class data reliability, and ultra-low power and ease of use required for industrial automation applications.

6.1 Dynamic Network Optimization

Dynamic network optimization allows the LTP5903-WHR to address the changing RF requirements in harsh industrial environments resulting in a network that is continuously self-monitoring and self-adjusting. The LTP5903-WHR manager performs dynamic network optimization based upon periodic reports on network health and link quality that it receives from the network motes. The manager uses this information to provide performance statistics to the application layer and proactively solve problems in the network. Dynamic network optimization not only maintains network health, but also allows the LTP5903-WHR to deliver deterministic power management.

6.2 Deterministic Power Management

Deterministic power management balances traffic in the network by diverting traffic around heavily loaded motes (for example, motes with high reporting rates). In doing so, it reduces power consumption for these motes and balances power consumption across the network. Deterministic power management provides predictable maintenance schedules to prevent down time and lower the cost of network ownership. When combined with field devices using Dust Network's industry-leading low power radio technology, deterministic power management enables over a decade of battery life for network motes.

6.3 Intelligent Routing

Intelligent routing provides each packet with an optimal path through the network. The shortest distance between two points is a straight line, but in RF the quickest path is not always the one with the fewest hops. Intelligent routing finds optimal paths by considering the link quality (one path may lose more packets than another) and the retry schedule, in addition to the number of hops. The result is reduced network power consumption, elimination of in-network collisions, and unmatched network scalability and reliability.

6.4 Bandwidth Flexibility

Efficient use of network resources enables Dust Networks to deliver bandwidth flexibility—the ability to assign different levels of bandwidth to satisfy unique throughput and latency requirements. Bandwidth flexibly addresses the range of latency and throughput needs of industrial automation applications such as request/response, fast file transfer, and alerting.

7.0 Interfaces

The LTP5903-WHR is designed for ease of integration by providing multiple data ports and well-defined software APIs. Section 7.1 describes the LTP5903-WHR data ports, LEDs, and switches. Section 7.1.6 describes the software functions that are available through the data ports.

7.1 Hardware Interfaces

Table 15 Hardware Interface Summary

Port	Description	Pins
Ethernet	10/100Base-T Ethernet	RX_P, TX_P, RX_N, TX_N, RX_CT, TX_CT, nACT_LED, nLINK_LED
Serial 1	UART 5-pin	S1_TX, S1_RX, GND
Serial 2	UART 9-pin	S2_TX, S2_RX, S2_RTS, S2_CTS, GND
LED Status Indicator	Status indicators	nLED_SUB, nLED_RADIO, nLED_JOIN, $\overline{\text{RST}}$

SD	External memory card	SD_CS0, SD_CLK, SD_MOSI, SD_MISO, SD_CD, SD_WP
----	----------------------	--

7.1.1 10/100Base-T Ethernet Interface

Ideal for remote or high-bandwidth access, the Ethernet interface provides full configuration management and data access to the LTP5903-WHR. The port connects to an IEEE 802.3 standard 10/100Base-T PHY, accessible through the board-to-board J10 connector. An appropriate Ethernet design requires magnetics and an RJ-45 connector.

RX_P and RX_N are the receive-side differential pair (see section 8.2 for pinout). The Rx and Tx levels conform to 10/100Base-T Ethernet.

7.1.2 Serial 1 Interface

The Serial 1 interface is designed for embedded integration with controllers. This serial interface provides programmatic access for configuration, management, and data access to the LTP5903-WHR. The port is a 5-pin LVTTTL (3.3 V) serial interface accessible through the board-to-board J10 connector.

Table 16 Serial 1 Parameters

Parameter	Value
Bit rate	115200
Parity	N
Data bits	8
Stop bit	1
Flow control	None

7.1.3 Serial 2 Interface

The LTP5903-WHR provides a UART interface with TX, RX, RTS, and CTS lines through the board-to-board J6 connector, operating up to 115 kbps.

Table 17 Serial 2 Parameters

Parameter	Value
Bit rate	115200
Parity	N
Data bits	8

Parameter	Value
Stop bit	1
Flow control	None

7.1.4 SD Card Interface

The SD Card interface, in conjunction with an PHY interface implemented per the [LTP5903IPC Integration Guide](#) has been tested against a range of commercially available SD cards and operates per limitations described in the “Datalog Utility” section of the [SmartMesh WirelessHART User Guide](#). The SD Card interface enables a portable non-volatile storage solution, targeting data logging applications.

7.1.5 LED Status Indicators

The LTP5903-WHR has LED status indicators on the top surface of the module, whose signals also pass through the board-to-board J10 connector.

Table 18 LED Status Indicators

LED Name	Signal Name	Description	Color
Power		Indicates 3.3V DC-DC converter is okay, lights when 5 V supply is connected	Green
$\overline{\text{RST}}$	nRESET_IN	Indicates the manager is in the reset state	Red

7.1.6 Restore Signal

The LTP5903-WHR supports the ability to restore its configuration settings to the Dust factory defaults. This feature is most useful in non-embedded applications where the LTP5903-WHR configuration may be different per installation (for example, a manager’s IP setting is forgotten and therefore unreachable). Note that while the restore feature may be used to recover a previously “unreachable” manager, all customizations to the manager will be lost, including configuration, logs, OTAP directory files, and persistent mote information.

The following factory default settings are restored:

- IP address
- PPP settings
- Serial port settings
- User name and password
- Wireless network and mote configuration settings
- Wireless network ID and common join key
- Access control list (cleared)
- Log files (cleared)
- Mote list (cleared)

The Restore Switch signal input to the LTP5903-WHR includes a debounce circuit to support direct connection to a mechanical push button, as illustrated in Figure 1.

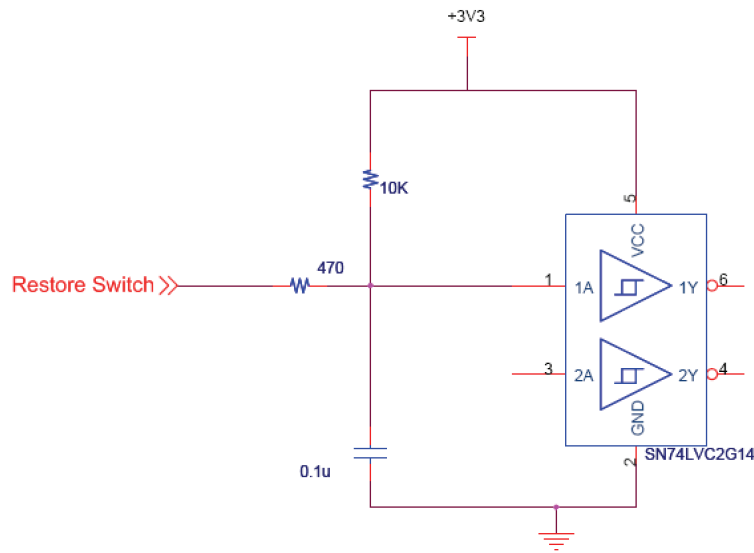

Figure 1 Restore Switch Debounce Input Stage

The Restore Switch signal controls the restore function. The Restore Switch signal is only active for the first three seconds after nRESET_IN is released. Usage of the Restore Switch signal is optional. If unused, the Restore Switch signal may be left unconnected, since it is internally pulled inactive high.

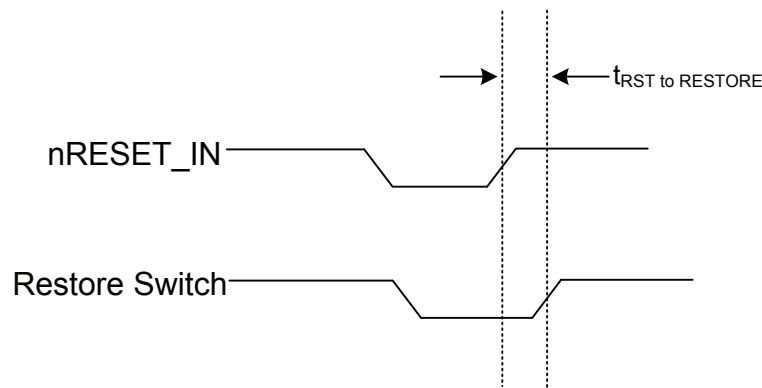

Figure 2 Restore Switch Signal Timing Diagram

Table 19 Restore Signal Timing Values

Parameter	Min	Typ	Max	Units	Comments
$t_{\text{RST to RESTORE}}$	1		20	s	

7.2 Software Interfaces

The LTP5903-WHR provides well-defined software interfaces for easy integration. Table 20 describes which interfaces are available via the various hardware ports. This section describes the software interfaces available via the hardware ports described in section 7.2.1.

Table 20 LTP5903-WHR Software Interfaces

Hardware Port	Software Interface	Comments
Ethernet	XML API, Admin Toolset	
Serial 1	<reserved>	
Serial 2	Command line interface	

7.2.1 XML API

The XML API is an open Extensible Markup Language (XML) interface that lets a client application send Remote Procedure Call (RPC) requests to the LTP5903-WHR and receive responses and other data from the LTP5903-WHR via XML-RPC. The API consists of a Control Channel and a Notification Channel. The Control Channel is used to establish connection and exchange commands and information about the SmartMesh Network. The Notification Channel is used to stream data and network events to the client program

7.2.2 Admin Toolset

The LTP5903-WHR provides a Web-based administrative tool called Admin Toolset. Through this interface, users may configure IP settings, view logs, manually configure the system time, or enable the Network Time Protocol (NTP) client. Users may also update LTP5903-WHR software as well as perform remote software updates on motes in the wireless network.

7.2.3 Command Line Interface

The command line interface is for troubleshooting with the assistance of Dust Networks support.

8.0 Board-to-board Connectors

The LTP5903-WHR has two 40-pin FCI/Berg 61083-042400LF board-to-board connectors. For connector and pin locations, see Figure 3 and Figure 4.

8.1 Connector Pin Numbering

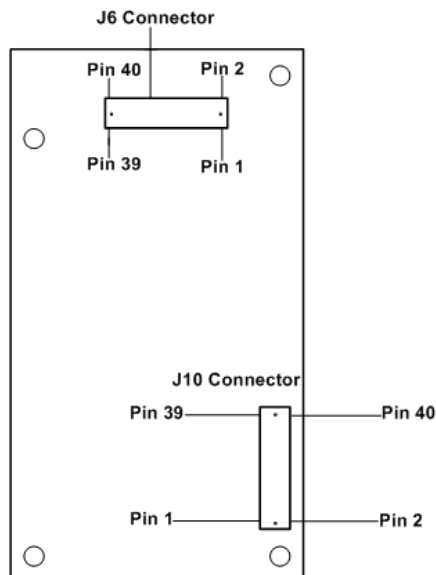

Figure 3 Connector Pin Numbering (Bottom View)

8.2 Pinout

Table 22 J10 Board-to-board Connector

Pin Number	Pin Name	I/O Direction	I/O Level	Interface Name
1	GND			
2	GND			
3	RX_P	In	10/100Base-T	Ethernet
4	TX_P	Out	10/100Base-T	Ethernet
5	RX_N	In	10/100Base-T	Ethernet
6	TX_N	Out	10/100Base-T	Ethernet
7	RX_CT	In	10/100Base-T	Ethernet
8	TX_CT	Out	10/100Base-T	Ethernet
9	nACT_LED	Out	LVTTL Type 3	LED Status indicators
10	nLINK_LED	Out	LVTTL Type 3	LED Status indicators
11	+3V3	Out	3.3 V \pm 5%	3.3 V Out
12	+3V3	Out	3.3 V \pm 5%	3.3 V Out
13	<i>Reserved</i>			Do not connect
14	<i>Reserved</i>			Do not connect
15	<i>Reserved</i>			Do not connect
16	<i>Reserved</i>			Do not connect
17	S1_TX	Out	LVTTL Type 1	Serial 1
18	<i>Reserved</i>			Do not connect
19	S1_RX	In	LVTTL Type 1	Serial 1
20	Restore Switch	In*	LVTTL Type 2	Switch In
21	GND			
22	nLED_SUB	Out	LVTTL Type 1	LED status indicators
23	SD_CLK	Out	LVTTL Type 1	SD clock
24	nLED_JOIN	Out	LVTTL Type 1	LED status indicators
25	+3V3	Out	3.3 V \pm 5%	3.3 V Out
26	<i>Reserved</i>			Do not connect
27	SD_CD		LVTTL Type 1	SD Card detect
28	<i>Reserved</i>			Do not connect
29	<i>Reserved</i>			Do not connect
30	SD_CS0	Out	LVTTL Type 1	SD Card chip select
31	SD_WP		LVTTL Type 1	SD Card write protect
32	<i>Reserved</i>			Do not connect
33	GND			
34	<i>Reserved</i>			Do not connect
35	SD_MISO		LVTTL Type 1	SD Card data in
36	<i>Reserved</i>			Do not connect
37	SD_MOSI		LVTTL Type 1	SD Card data out
38	<i>Reserved</i>			Do not connect
39	GND			
40	GND			

* Input includes a debounce input stage as illustrated in Figure 1.

Table 23 J6 Board-to-board Connector

Pin Number	Pin Name	I/O Direction	I/O Level	Interface Name
1	GND			
2	GND			
3	<i>Reserved</i>			Do not connect
4	S2_TX	Out	LVTTL Type 1	Serial 2
5	<i>Reserved</i>			Do not connect
6	S2_RX	In	LVTTL Type 1	Serial 2
7	<i>Reserved</i>			Do not connect
8	S2_RTS	Out	LVTTL Type 1	Serial 2
9	<i>Reserved</i>			Do not connect
10	S2_CTS	In	LVTTL Type 1	Serial 2
11	<i>Reserved</i>			Do not connect
12	<i>Reserved</i>			Do not connect
13	<i>Reserved</i>			Do not connect
14	<i>Reserved</i>			Do not connect
15	GND			
16	<i>Reserved</i>			Do not connect
17	<i>Reserved</i>			Do not connect
18	<i>Reserved</i>			Do not connect
19	<i>Reserved</i>			Do not connect
20	+3V3	Out	3.3 V ± 5%	3.3 V Out
21	+3V3	Out	3.3 V ± 5%	3.3 V Out
22	nRESET_OUT	Out	LVTTL Type 4	Reset low out
23	<i>Reserved</i>			Do not connect
24	GND			
25	<i>Reserved</i>			Do not connect
26	RESET_OUT	Out	LVTTL Type 4	Reset high out
27	<i>Reserved</i>			Do not connect
28	nRESET_IN	In**	LVTTL Type 5	Reset low in
29	<i>Reserved</i>			Do not connect
30	<i>Reserved</i>			Do not connect
31	<i>Reserved</i>			Do not connect
32	+5V_IN	In	5.0 V ± 5%	Power In
33	<i>Reserved</i>			Do not connect
34	+5V_IN	In	5.0 V ± 5%	Power In
35	GND			
36	+5V_IN	In	5.0 V ± 5%	Power In
37	nLED_RADIO	Out	LED	LED status indicators
38	<i>Reserved</i>			Do not connect
39	GND			
40	GND			

* Input includes a 10kΩ resistor pulled to +3V3.

8.3 Recommended Mating Connectors

The user connections are made through J6 and J10 on the LTP5903-WHR, which are FCI/Berg 61083-042400LF board-to-board connectors. The mating connector should be an FCI/Berg 61082-04x400LF, where 'x' depends on the desired stack height (see Table 24).

Table 24 Recommended Mating Connectors

Connector	Mated Height (mm)
FCI/Berg 61082-041400LF	6
FCI/Berg 61082-042400LF	10
FCI/Berg 61082-043400LF	14

9.0 Mechanical Specifications

9.1 LTP5903-WHR Mechanical Drawings

In laying out a design, locate the mating connectors by using the alignment pins and correlating pin numbers for orientation (see Figure 3).

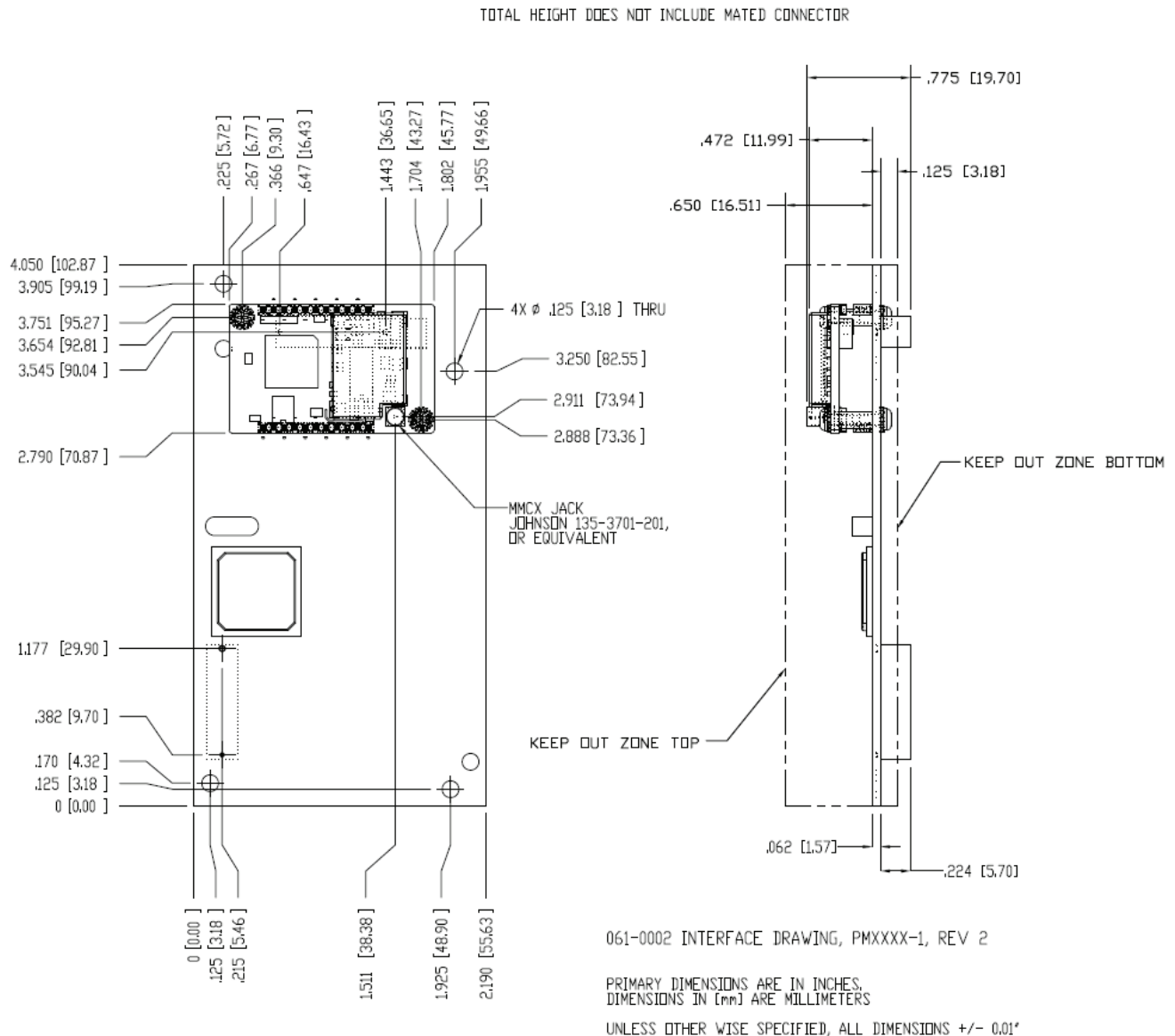
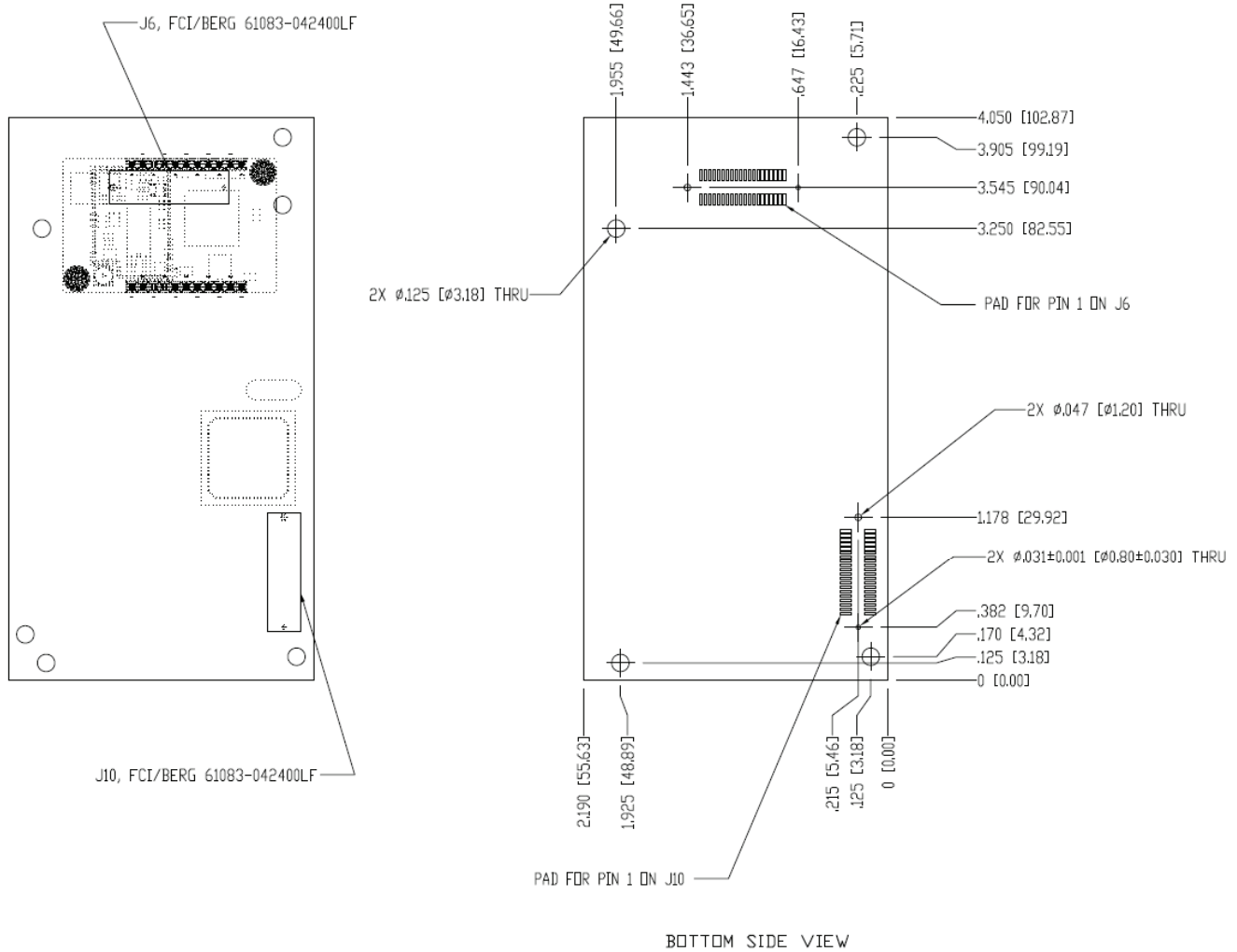

Figure 4 Top and Side Views



061-0002, INTERFACE DRAWING, PMXXX-1, REV 2
 PRIMARY DIMENSIONS ARE IN INCHES,
 DIMENSIONS IN [mm] ARE MILLIMETERS
 UNLESS OTHERWISE SPECIFIED, ALL DIMENSIONS +/- 0.01"

Figure 5 Bottom View

10.0 Regulatory and Standards Compliance

10.1 FCC Compliance

10.1.1 FCC Testing

The LTP5903-WHR Embedded Manager complies with Part 15.247 modular (Intentional Radiator) of the FCC rules and regulations. In order to fulfill FCC certification requirements, products incorporating the LTP5903-WHR Embedded Manager must comply with the following:

1. An external label must be provided on the outside of the final product enclosure specifying the FCC identifier, as described in section 10.1.3 below.
2. The antenna must be electrically identical to the FCC-approved antenna specifications for the LTP5903-WHR as described in 10.1.2, with the exception that the gain may be lower than specified in Table 25.

3. The device integrating the LTP5903-WHR may not cause harmful interference, and must accept any interference received, including interference that may cause undesired operation.
4. An unintentional radiator scan must be performed on the device integrating the LTP5903-WHR Embedded Manager, per FCC rules and regulations, CFR Title 47, Part 15, Subpart B. See FCC rules for specifics on requirements for declaration of conformity.

10.1.2 FCC-approved Antenna

The following are FCC-approved antenna specifications for the LTP5903-WHR.

Table 25 FCC-approved Antenna Specifications for the LTP5903-WHR

Gain	Pattern	Polarization	Frequency	Connector
+2 dBi maximum	Omni-directional	Vertical	2.4–2.4835 GHz	MMCX

10.1.3 OEM Labeling Requirements

The Original Equipment Manufacturer (OEM) must ensure that FCC labeling requirements are met. The outside of the final product enclosure must have a label with the following (or similar) text specifying the FCC identifier. The FCC ID and certification code must be in Latin letters and Arabic numbers and visible without magnification.

Contains transmitter module FCC ID: SJC-M2140

or

Contains FCC ID: SJC-M2140

10.2 IC Compliance

10.2.1 IC Testing

The LTP5903-WHR is certified for modular Industry Canada (IC) RSS-210 approval. The OEM is responsible for its product to comply with IC ICES-003 and FCC Part 15, Sub. B - Unintentional Radiators. The requirements of ICES-003 are equivalent to FCC Part 15 Sub. B and Industry Canada accepts FCC test reports or CISPR 22 test reports for compliance with ICES-003.

10.2.2 IC-approved Antennae

The LTP5903-WHR is designed to operate with antennas meeting the specifications shown in Table 26. Antennas not meeting these specifications are strictly prohibited for use with the LTP5903-WHR. The required antenna impedance is 50 Ohms. Operation is subject to the following two conditions: (1) this device may not cause interference, and (2) this device must accept any interference, including interference that may cause undesired operation of the device.

Table 26 IC-approved Antenna Specifications for the LTP5903-WHR

Gain	Pattern	Polarization	Frequency	Connector
+2 dBi maximum	Omni-directional	Vertical	2.4–2.4835 GHz	MMCX

The following are IC-approved antenna specifications for the LTP5903-WHR.

10.2.3 OEM Labeling Requirements

The Original Equipment Manufacturer (OEM) must ensure that IC labeling requirements are met. The outside of the final product enclosure must have a label with the following (or similar) text specifying the IC identifier. The IC ID and certification code must be in Latin letters and Arabic numbers and visible without magnification.

Contains IC: 5853A-M2140

10.3 CE Compliance

10.3.1 Declaration of Conformity

We, Dust Networks, of 30695 Huntwood Ave, Hayward, CA 94544 USA, declare under our sole responsibility that our product, SmartMesh WirelessHART LTP5903-WHR, and in combination with our accessories, to which this declaration relates is in conformity with the appropriate standards ETSI EN 300 328, ETSI EN 301 489-17 and EN 60950, following the provisions of Radio Equipment and Telecommunication Terminal Equipment Directive 99/5/EC with requirements covering EMC Directive 2004/108/EC, and Low Voltage Directive 2006/95/EC.

10.3.2 European Compliance

If the LTP5903-WHR managers are incorporated into a product, the manufacturer must ensure compliance of the final product to the European harmonized EMC and low-voltage/safety standards. A Declaration of Conformity must be issued for each of these standards and kept on file as described in Annex II of the R&TTE Directive. Furthermore, the manufacturer must maintain a copy of this LTP5903-WHR user documentation and ensure the final product does not exceed the specified power ratings, antenna specifications, and/or installation requirements as specified in the user manual. If any of these specifications are exceeded in the final product, a submission must be made to a notified body for compliance testing to all required standards.

10.3.3 OEM Labeling Requirements

The 'CE' marking must be affixed to a visible location on the OEM product. The CE mark shall consist of the initials "CE" taking the following form:

- If the CE marking is reduced or enlarged, the proportions given in the drawing below must be respected.
- The CE marking must have a height of at least 5 mm except where this is not possible on account of the nature of the apparatus.
- The CE marking must be affixed visibly, legibly, and indelibly.

Furthermore, since the usage of the 2400 – 2483.5 MHz band is not harmonized throughout Europe, the Restriction sign must be placed to the right of the 'CE' marking as shown below. See the R&TTE Directive, Article 12 and Annex VII for more information.

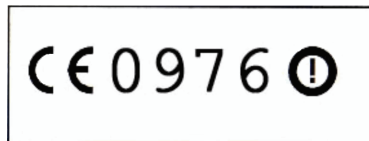

Figure 6 CE Label Requirements



10.3.4 Restrictions

Norway prohibits operation near Ny-Alesund in Svalbard. More information can be found at the Norway Posts and Telecommunications site (www.npt.no).

10.4 Compliance to Japan Radio Law

The M2510 modular radio incorporated in the LTP5903-WHR is compliant to Japan Radio Law Article 38, Section 24.

10.4.1 OEM Labeling Requirements

The Original Equipment Manufacturer (OEM) must ensure that Japan Radio Law labeling requirements are met. The outside of the final product enclosure must have a label including the Mark, , and the  symbol indicating radio equipment and the identification code as follows:

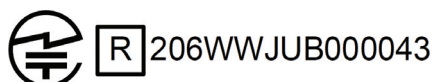



Figure 7 JRL Label Requirements

The Mark, , must be reproduced with a minimum diameter of 3mm.

10.4.2 Antenna Selection

The LTP5903-WHR incorporating the M2510 module may be used with the following antennas:

Table 27 Japan Approved Antennas

Manufacturer	Part #	Peak Gain
Fractus	FR05-S1-N-0-102	1.5 dBi
Nearson	S181XX-2450S	2 dBi

10.5 Compliance to Restriction of Hazardous Substances (RoHS)

Restriction of Hazardous Substances (RoHS) is a directive that places maximum concentration limits on the use of certain hazardous substances in electrical and electronic equipment. Linear Technology is committed to meeting the requirements of the European Community directive 2002/95/EC.

This product has been specifically designed to utilize RoHS compliant materials and to eliminate, or reduce, the use of restricted materials to comply with 2002/95/EC.

The Linear Technology RoHS compliant design features include:

- RoHS compliant solder for solder joints
- RoHS compliant base metal alloys
- RoHS compliant precious metal plating
- RoHS compliant cable assemblies and connector choices

10.6 Industrial Environment Operation

The LTP5903-WHR is designed to meet the specifications of a harsh industrial environment that includes:

- **Shock and Vibration**—The LTP5903-WHR complies with high vibration pipeline testing, as specified in IEC 60770-1.
- **Temperature Extremes**—The LTP5903-WHR is designed for industrial storage and operational temperature range of -40°C to $+85^{\circ}\text{C}$.

11.0 Order Information

LEAD FREE FINISH**	PART MARKING	PACKAGE DESCRIPTION	TEMPERATURE RANGE
LTP5903IPC-WHRB???	LTP5903	4.050" x 2.190" x 0.775 PCB	-40°C to 85°C
LTP5903IPC-WHRC???	LTP5903	4.050" x 2.190" x 0.775 PCB	-40°C to 85°C

** See www.linear.com/ltp5903-whr#orderinfo or contact your sales representative to determine the three digit software version field, ???.

For more information on lead free part marking, go to: <http://www.linear.com/leadfree/>

12.0 Related Documentation

- [LTP5903IPC Integration Guide](#)

Copyright

This documentation is protected by United States and international copyright and other intellectual and industrial property laws. It is solely owned by Dust Networks, Inc. and its licensors and is distributed under a restrictive license. This product, or any portion thereof, may not be used, copied, modified, reverse assembled, reverse compiled, reverse engineered, distributed, or redistributed in any form by any means without the prior written authorization of Dust Networks, Inc.

RESTRICTED RIGHTS: Use, duplication, or disclosure by the U.S. Government is subject to restrictions of FAR 52.227-14(g) (2)(6/87) and FAR 52.227-19(6/87), or DFAR 252.227-7015 (b)(6/95) and DFAR 227.7202-3(a), and any and all similar and successor legislation and regulation.

Disclaimer

This documentation is provided “as is” without warranty of any kind, either expressed or implied, including but not limited to, the implied warranties of merchantability or fitness for a particular purpose.

This documentation might include technical inaccuracies or other errors. Corrections and improvements might be incorporated in new versions of the documentation.

Dust Networks does not assume any liability arising out of the application or use of any products or services and specifically disclaims any and all liability, including without limitation consequential or incidental damages.

Dust Networks products are not designed for use in life support appliances, devices, or other systems where malfunction can reasonably be expected to result in significant personal injury to the user, or as a critical component in any life support device or system whose failure to perform can be reasonably expected to cause the failure of the life support device or system, or to affect its safety or effectiveness. Dust Networks customers using or selling these products for use in such applications do so at their own risk and agree to fully indemnify and hold Dust Networks and its officers, employees, subsidiaries, affiliates, and distributors harmless against all claims, costs, damages, and expenses, and reasonable attorney fees arising out of, directly or indirectly, any claim of personal injury or death associated with such unintended or unauthorized use, even if such claim alleges that Dust Networks was negligent regarding the design or manufacture of its products.

Dust Networks reserves the right to make corrections, modifications, enhancements, improvements, and other changes to its products or services at any time and to discontinue any product or service without notice. Customers should obtain the latest relevant information before placing orders and should verify that such information is current and complete. All products are sold subject to Dust Network's terms and conditions of sale supplied at the time of order acknowledgment or sale.

Dust Networks does not warrant or represent that any license, either express or implied, is granted under any Dust Networks patent right, copyright, mask work right, or other Dust Networks intellectual property right relating to any combination, machine, or process in which Dust Networks products or services are used. Information published by Dust Networks regarding third-party products or services does not constitute a license from Dust Networks to use such products or services or a warranty or endorsement thereof. Use of such information may require a license from a third party under the patents or other intellectual property of the third party, or a license from Dust Networks under the patents or other intellectual property of Dust Networks.

Dust Networks, Inc is a wholly owned subsidiary of Linear Technology Corporation.

© Dust Networks, Inc. 2013. All Rights Reserved.

Document Number: 020-0051 rev 5 SmartMesh WirelessHART LTP5903-WHR Datasheet

Last Revised: November 1, 2013

Document Status	Product Status	Definition
Advanced Information	Planned or under development	This datasheet contains the design specifications for product development. Dust Networks reserves the right to change specifications in any manner without notice.
Preliminary	Engineering samples and pre-production prototypes	This datasheet contains preliminary data; supplementary data will be published at a later time. Dust Networks reserves the right to make changes at any time without notice in order to improve design and supply the best possible product. The product is not fully qualified at this point.
No Identification Noted	Full production	This datasheet contains the final specifications. Dust Networks reserves the right to make changes at any time without notice in order to improve design and supply the best possible product.
Obsolete	Not in production	This datasheet contains specifications for a product that has been discontinued by Dust Networks. The datasheet is printed for reference information only.